

ABOUT THIS MANUAL

VISION CREATIVE, INC.

서울 중로구 통의동
6번지 이룸빌딩 4층

담 당	김영진 님	ITEM	I-MANUAL
F.MODEL	KQG-8A6K5S40	브랜드	DAEWOO
B.MODEL	KQG-8A6K5S40	언 어	영어
BUYER	영문기본	COUNTRY	
SET LABEL LIST 발행 No.			
DESIGN DOCUMENT No.			
일 정	1차		
	2차		
	3차		
	4차		
	5차		
제 판	한	인쇄	
MEMO 총 27p 10.12.21-표지, 1p, 7p, 8p, 10p _ 신규 5p			

연락처

VISION 담당 방문수

TEL: 730-0660 FAX: 730-3788

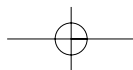



MICROWAVE OVEN

KQG-8A6K5S40

**OWNER'S
MANUAL**

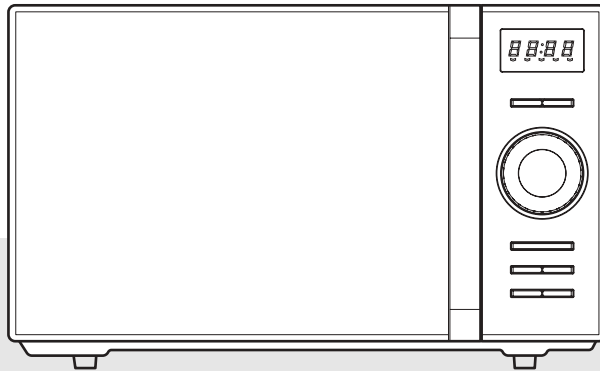

Before operating this oven, please read these instructions completely.

PRECAUTIONS TO AVOID POSSIBLE EXPOSURE TO EXCESSIVE MICROWAVE ENERGY

- (a) **Do not attempt to operate this oven with the door open** since open-door operation can result in harmful exposure to microwave energy. It is important not to defeat or tamper with the safety interlocks.
- (b) **Do not place any object** between the oven front face and the door or allow soil or cleaner residue to accumulate on sealing surfaces.
- (c) **WARNING** : If the door or door seals are damaged, the oven must not be operated until it has been repaired by a competent person: (1) door (bent), (2) hinges and latches (broken or loosened), (3) door seals and sealing surfaces.
- (d) **WARNING** : It is hazardous for anyone other than a competent person to carry out any service or repair operation which involves the removal of a cover which gives protection against exposure to microwave energy.
- (e) **WARNING** : Liquids and other foods must not be heated in sealed containers since they are liable to explode.
- (f) **WARNING** : Only allow children to use the oven without supervision when adequate instructions have been given so that the child is able to use the oven in a safe way and understands the hazards of improper use.
- (g) **WARNING** : When the appliance is operated in the combination mode, children should only use the oven under adult supervision due to the temperatures generated.

TABLE OF CONTENTS

<ul style="list-style-type: none"> • INSTALLATION AND EARTHING INSTRUCTIONS.....2 • IMPORTANT SAFETY INSTRUCTONS3 • WHICH UTENSILS CAN BE USED IN THE OVEN? ..5 • COOKING INSTRUCTIONS.....6 • CONTROL PANEL7 • FEATURES DIAGRAM8 • OPERATION PROCEDURE9 • CONTROLS10 QUICK DEFROST.....10 AUTO DEFORST10 CHILLED MEAL.....11 GRILL/COMBI.....12 MICRO POWER.....13 EXPRESS COOK.....13 AUTO COOK14 NIGHT LIGHT15 CHILD SAFETY LOCK15 HOW TO STOP THE OVEN WHILE THE OVEN IS OPERATING.....15 ARCING15 	<ul style="list-style-type: none"> • GENERAL GUIDE LINES16 • CARE AND CLEANING17 • BEFORE CALLING FOR SERVICE18 • QUESTIONS AND ANSWERS19 • SPECIFICATIONS.....20 • PRINCIPLE OF MICROWAVE20 • DISPOSAL OF USED ELECTRICAL & ELECTRONIC EQUIPMENT20 • COOKING TECHNIQUES21 • DEFROSTING GUIDE22 • COOKING & REHEATING CHART23 • VEGETABLE CHART24 • RECIPES25-26
---	--

INSTALLATION AND EARTHING INSTRUCTIONS

How to examine your microwave oven after unpacking.

Unpack oven, remove all packing material, and examine the oven for any damage such as dents, broken door, latches or cracks in the door. Do not remove the film from inside the door. Notify dealer immediately if the oven is damaged. Do not install if the oven is damaged.

Where to place your microwave oven.

1. Place the oven on a flat and stable surface.
2. The microwave oven shall not be placed in a cabinet unless it is a purpose built cabinet model.
3. The surface of the oven is protected by a plastic film which should be removed before using.
4. Leave space behind and the sides and upper surface of the oven. All air vents should be kept clear.
If all vents are covered during operation, the oven may overheat and, eventually, lead to oven failure.
5. Keep away from radio and TV sets. If the oven is located close to a TV, radio interference may result.
6. Keep away from heating appliances and water taps. Keep the oven away from hot air, steam or splashes when choosing a place to position it, or the insulation might be adversely affected and breakdowns occur.
7. The minimum height of free space necessary above the top surface of the oven is 100mm minimum.

Prior to use (If your oven has a grill element)

In order to protect your oven during transportation and storage, the grill element is covered with a protective coating. To remove this coating the grill element must be heated for 10 minutes. This procedure will produce some bad odours as the protective coating on the element disappears.

To remove the coating, use the following procedures:

1. Place an ovenproof or microwave safe bowl, containing 200cc of water or more, in the oven.
2. Press the grill button.
3. Set the time to 10 minutes.
4. Press the start button.
5. When the 10 minutes has elapsed, an acoustic signal sounds.

Note:

The protective coating has now been removed and the oven is ready to use. Please be aware that your oven is now very hot.

6. Open the oven door and remove the bowl of water (use oven gloves when removing the bowl).

CHILD LOCK

To prevent a child from operating the oven, install the childlock key.

1. Touch Stop/Clear button for 3 seconds.
Indicator lock is indicated and all buttons do not operate.
2. Touch Stop/Clear button for 3 seconds once again, then childlock is canceled.

- **WARNING:** Only allow children to use the oven without supervision when adequate instructions have been given so that the child is able to use the oven in a safe way and understands the hazards of improper use.

Electrical Connection

WARNING-THIS APPLIANCE MUST BE EARTHED.

REFER TO THE RATING PLATE FOR VOLTAGE AND CHECK THAT THE APPLIANCE VOLTAGE CORRESPONDS WITH THE SUPPLY VOLTAGE IN YOUR HOME.

The flexible mains lead must be correctly re-connected, as below, to a three pin plug of not less than 13 AMP capacity. You must use a 2 pin plug which should be marked with the number BS 1363 and it

should be fitted with 13 AMP fuse marked with the number BS 1362. We recommend the use of good quality plugs and wall sockets that can be switched off when the machine is not in use.

IMPORTANT-The wires in the mains lead fitted to this appliance are coloured in accordance with the following code

GREEN AND YELLOW-EARTH
BLUE-NEUTRAL
BROWN-LIVE

As the colour of the wires in the mains lead of this appliance may not correspond with the coloured markings identifying the terminals in your plug, proceed as follows:

Power supply

- Check your local power source. This oven requires a current of approximately 6amperes, 230V 50Hz.
- Power supply cord is about 1.0 meters long.
- The voltage used must be the same as specified on this oven. Using a higher voltage may result in a fire or other accident causing oven damage. Using low voltage will cause slow cooking. We are not responsible for damage resulting from use of this oven with a voltage of ampere fuse other than those specified.
- If the supply cord is damaged, it must be replaced by the manufacturer or its service agent or a similarly qualified person in order to avoid a hazard.

The wire which is coloured GREEN AND YELLOW must be connected to the terminal in the plug which is marked with the letter "E" or the earth symbol \equiv or coloured GREEN AND YELLOW, or GREEN.

The wire which is coloured BLUE must be connected to the terminal which is marked with the letter "N" or coloured BLACK, or BLUE. The wire which is coloured BROWN must be connected to the terminal which is marked with the letter "L" or coloured RED, or BROWN.

If the terminals in the plug are unmarked or you are in any doubt as to the correct connections, consult a qualified electrician.

If you do not make the proper electrical connections you will damage your microwave oven and possibly injure yourself. Neither the manufacturer nor the supplier are liable if this happens.

MOULDED PLUGS

Should it be necessary to remove a moulded on plug from the mains cable, it should be cut off and replaced with a suitable replacement.

The moulded plug cannot be used for any other appliance, therefore remove the fuse and dispose immediately and safely to prevent anyone, especially children from plugging it in to a wall socket, which will create a safety hazard.

Should the mains lead ever require replacement, it is essential that this operation be carried out by a qualified electrician and should only be replaced with a flexible cord obtained from the manufacturer.

Applicable only if moulded plug is fitted.

After replacement of a fuse in the plug, the fuse cover must be refitted. If the fuse cover is lost, a replacement cover must be obtained. The colour of the correct replacement fuse cover is that of the coloured insert in the base of the plug or the colour that is embossed in words in the base of the plug recess or elsewhere on the plug. Always state this colour when ordering a replacement fuse cover.

Only 13 amp replacement fuses which are ASTA approved to BS 1362 should be fitted

IMPORTANT SAFETY INSTRUCTIONS

READ CAREFULLY AND KEEP FOR FUTURE REFERENCE

When using electrical appliances, basic safety precautions should be followed, including the following:

WARNING-To reduce the risk of burns, electric shock, fire, injury to persons or exposure to excessive microwave energy:

1. Read all instructions before using the appliance.
2. Read and follow the specific "PRECAUTIONS TO AVOID POSSIBLE EXPOSURE TO EXCESSIVE MICROWAVE ENERGY" found on page 1.
3. This appliance must be grounded. Connect only to a properly grounded outlet.
4. Install or locate this appliance only in accordance with the provided installation instructions.
5. Some products such as whole eggs and sealed containers - for example, closed glass jars-are liable to explode and should not be heated in this oven.
6. Use this appliance only for its intended use as described in this manual. Do not use corrosive chemicals or vapors in this appliance. This type of oven is specifically designed to heat, cook, or dry food. It is not designed for industrial or laboratory use.
7. As with any appliance, close supervision is necessary when used by children.
8. Do not operate this appliance if it has a damaged cord or plug, if it is not working properly, or if it has been damaged or dropped.
9. This appliance should be serviced only by qualified service personnel.

Contact your nearest authorized service facility for examination, repair or adjustment.
10. Do not cover or block any openings on the appliance.
11. Do not store this appliance outdoors. Do not use this product near water — for example, near a kitchen sink, in a wet basement, or near a swimming pool, or similar locations.
12. Do not immerse the cord or plug in water.
13. Keep the cord away from heated surfaces.
14. Do not let cord hang over edge of table or counter.
15. Either:
 - a) When cleaning surfaces of door and oven that comes together on closing the door, use only mild, non-abrasive soaps or detergents applied with a sponge or soft cloth , or
 - b) When separate cleaning instructions are provided, See door surface cleaning instructions on.
16. To reduce the risk of fire in the oven cavity:
 - a) Do not overcook food. Carefully attend the appliance when paper, plastic, or other com-bustible materials are placed inside the oven to facilitate cooking.
 - b) Remove wire twist-ties from paper or plastic bags before placing bag in the oven.
 - c) If materials inside the oven ignite, keep oven door closed, turn oven off, and disconnect the power cord, or shut off power at the fuse or circuit breaker panel.
17. Do not use this microwave oven to heat corrosive chemicals (for example, sulfides and chlorides). Vapours from such corrosive chemicals may interact with the contact and springs of the safety interlock switches thereby rendering them inoperable.
18. Keep the waveguide cover clean at all times. Wipe the oven interior with a soft damp cloth after each use. If you leave grease or fat anywhere in the cavity it may overheat, smoke or even catch fire when next using the oven.
19. Never heat oil or fat for deep frying as you cannot control the temperature and doing so may lead to overheating and fire.
20. Liquids, such as water, coffee, or tea are able to be overheated beyond the boiling point without appearing to be boiling due to surface tension of the liquid. Visible bubbling or boiling when the container is removed from the microwave oven is not always present. **THIS COULD RESULT IN VERY HOT LIQUIDS SUDDENLY BOILING OVER WHEN A SPOON OR OTHER UTENSIL IS INSERTED INTO THE LIQUID.** To reduce the risk of injury to persons:
 - ① Do not overheat the liquid.
 - ② Stir the liquid both before and halfway through heating it
 - ③ Do not use straight-sided containers with narrow necks.
 - ④ After heating, allow the container to stand in the microwave oven for a short time before removing the container.
 - ⑤ Use extreme care when inserting a spoon or other utensil into the container.
21. The contents of feeding bottles and baby jars must be stirred or shaken and check the temperature before consumption to avoid burns.
22. The appliance must be positioned so that the plug is accessible.
23. This appliance is not intended for use by a person (including children) with reduced physical, sensory or mental capabilities, or lack of experience and knowledge, unless they have been given supervision or instruction concerning use of the appliance by a person responsible for their safety.
24. Children should be supervised to ensure that they do not play with the appliance.

SAVE THESE INSTRUCTIONS

General Use

Listed below are, as with all appliances, certain rules to follow and safeguards to assure top performance from this oven:

1. Do not use the oven for any reason other than food preparation, such as for drying clothes, paper, or any other nonfood items or for sterilizing purposes.
They may catch on fire.
2. Do not use the oven when empty, this could damage the oven.
3. Do not use the oven cavity for any type of storage, such as papers, cookbook, cookware, etc.
4. Do not operate the oven without the turntable tray in place. Be sure it is properly sitting on the rotating base.
5. Be cautious when removing the turntable tray after cooking meats that may have caused an accumulation of grease in the tray.
6. Unlike microwave-only ovens, this oven may become hot on the cabinet and oven door.
Always use hot pads or oven mitts when placing or removing food and/or accessories from the oven.
Be cautious about touching parts other than the control panel during or immediately following grill or combination cooking.
7. If the oven is hot from combination cooking, do not then use plastic or Styrofoam cookware for microwave cooking. They may melt.
8. Do not use recycled paper products for cooking. They may contain impurities which could cause sparks and/or fires when used during cooking.
9. Do not continue to cook with metal utensils if sparking appears. See "Accessories" section on page 8 for proper use of cookware.
10. Do not leave the oven unattended during short cooking times. Overcooking and fire may result.
11. Do not cook any food surrounded by a membrane, such as egg yolks, potatoes, chicken livers, etc., without first piercing them several times with a fork.
12. Do not pop popcorn unless popped in a microwave approved popcorn popper or unless it's commercially packaged and recommended especially for microwave ovens. Microwave popped corn produces a lower yield than conventional popping; there will be a number of unpopped kernels. Do not use oil unless specified by the manufacturer.
13. Do not attempt to operate this appliance with the door open.
14. Do not attempt to remove covers, panels, etc.
15. Keep an eye on the oven from time to time when food is heated or cooked in disposable containers of plastic, paper or other combustible materials.
16. If smoke is observed, switch off or unplug the appliance and keep the door closed in order to stifle any flames.
17. Microwave heating of beverages can result in delayed eruptive boiling, therefore care must be taken when handling the container.
18. Make sure you remove caps or lids prior to cooking when you cook food sealed in bottles.
19. Do not put foreign material between the oven surface and door. It could result in excessive leakage of microwave energy.
20. Do not pop popcorn longer than the manufacturer's directions. (popping time is generally below 3 minutes). Longer cooking does not yield more popped corn, it can cause scorchings and fire.
Also, the cooking tray can become too hot to handle or may break.
21. When heating food in plastic or paper containers, keep an eye on the oven due to the possibility of ignition.
22. Always test the temperature of food or drink which has been heated in a microwave oven before you give it to somebody, especially to children or elderly people. This is important because things which have been heated in a microwave oven carry on getting hotter even though the microwave oven cooking has stopped.
23. Eggs in their shell and whole hard-boiled eggs should not be heated in microwave ovens since they may explode, even after microwave heating has ended;
24. Keep the waveguide cover clean at all times.
Wipe the oven interior with a soft damp cloth after each use. If you leave grease or fat anywhere in the cavity it may overheat, smoke or even catch fire when next using the oven.
25. Never heat oil or fat for deep frying as you cannot control the temperature and doing so may lead to overheating and fire.
26. During use the appliance becomes hot. Care should be taken to avoid touching heating elements inside the oven.
27. Do not use a steam cleaner in the oven.

TO AVOID EXPLOSION AND SUDDEN BOILING

WARNING

Liquids, such as water, coffee, or tea are able to be overheated beyond the boiling point without appearing to be boiling due to surface tension of the liquid. Visible bubbling or boiling when the container is removed from the microwave oven is not always present. this could result in very hot liquids suddenly boiling over when a spoon or other utensils is inserted into the liquid.

To reduce the risk of injury to persons:

- a) Do not overheat the liquid.
- b) Stir the liquid both before and halfway through heating it
- c) Do not use straight-sided containers with narrow necks.
- d) After heating, allow the container to stand in the microwave oven for a short time before removing the container.
- e) Use extreme care when inserting a spoon or other utensil into the container.

1. Eggs

Never cook eggs in their shells. Steam will build up inside the shell during cooking and the egg will explode.

If you want to cook or reheat eggs which have not been broken up by scrambling or mixing, you must always pierce the yolks or these will also explode. You should slice shelled hard boiled eggs before you reheat them in your microwave oven.

2. Piercing

Always pierce food which has a skin or membrane, for example, potatoes, tomatoes, apples, sausages etc. If you don't pierce them, steam will build up inside and they may explode.

3. Lids

Always remove the lids of jars and containers and take away food containers, before you cook using your microwave oven. If you don't, then steam and pressure might build up inside and cause an explosion even after the microwave cooking has stopped.

WHICH UTENSILS CAN BE USED IN THE OVEN?

Only use utensils that are suitable for use in microwave ovens.

Before use, the user should check that utensils are suitable for use in microwave ovens.

Material	Grill & Convection cooking	Microwave cooking	Combined cooking
Glass (general)	No	Yes (1)	No
Glass (heat resistant)	Yes	Yes	Yes
Glass-ceramic and ceramic (heat resistant)	Yes	Yes (1)	Yes (1)
Earthenware	Yes	Yes	Yes
China (heat resistant)	Yes	Yes	Yes
Plastic (general)	No	Yes (2)	No
Plastic (heat resistant)	Yes (2)	Yes (2)	Yes (2)
Aluminium foil	Yes	Yes (3)	Yes
Metal baking tins	Yes (4)	No	Yes (4)
Metal (pots.pans, etc)	Yes	No	No
Paper	No	Yes	No

1. Without metal parts or metal trims.
2. Some plastics are heat-proof only to certain temperatures. Check carefully!
3. It is possible to use aluminium foil to shield delicate areas of food (this prevents over-cooking).
4. Metal tins can be used in the combination methods, however if these are very deep, they will greatly reduce the efficiency, as metal shields the microwave energy from the food.

Utensils made of china and ceramic are excellent to use in your microwave oven. Most types of glass are also very good.

Lead crystal glass can crack and should therefore, not be used.

Plastics and paper can also be used, provided they can withstand the temperature of the heated food. For cooking only use plastics, which will withstand a temperature of over 120°C, e.g. polypropene and polyamide. Some plastic materials, e.g. melamine, will be heated by the microwave, and be damaged. To find out if a certain container is suitable, the following simple test can be made:

Place the empty container and a glass of water inside the microwave oven. The water is needed because the oven must not be operated empty or with empty containers only.

Let the oven work on full power for one minute. A suitable container will only be lukewarm.

Metal containers, e.g. saucepans or frying pans should not be used in microwave ovens. Nor should plates or vessels with decorations be used since metal e.g. gold, might be part of the decoration and such decorations will be damaged.

Small pieces of aluminium foil can be used, but only to shield the areas that would over-cook (e.g. for covering chicken wings, leg tips and fish tails) but the foil must not touch the side of the oven as damage may occur.



Microwave function only

Utensils and cooking containers used in a microwave oven should be of a material that does not act as a barrier to microwave energy. Generally this means that you should cook in either (paper), plastic, glass or ceramic. Metal pans reflect microwave energy and inhibit cooking, and should not be used. In addition to material, the shape of the container should also be considered. Round oval shapes give the most even cooking. Square or rectangular containers may over-cook foods in the corners because more energy is absorbed there. Shallow containers give more even cooking results.

Caution:

- There are a number of accessories available on the market. Before you buy, make sure they are suitable for microwave use.
- When you put food in the microwave oven, make sure that food, food supports or covering do not come in direct contact with any of the internal walls or the ceiling of the cavity since discolouration may take place.

COOKING INSTRUCTIONS

Utensil Guide

Only use utensils that are suitable for use in microwave ovens.

To cook food in the microwave oven, the microwaves must be able to penetrate the food, without being reflected or absorbed by the dish used. Care must therefore be taken choosing the utensil. If the utensil is marked microwave-safe, you do not need to worry. The following table lists several of utensil and indicates whether and how they should be used in a microwave oven.

Utensil	Safe	Comments
Aluminium foil	▲	Can be used in small quantities to protect areas against overcooking. Arcing can occur if the foil is too close to the oven wall or if too much foil is used.
Crust plate	●	Do not preheat for more than 8minutes.
China and earthenware	●	Porcelain, pottery, glazed earthenware and bone china are usually suitable, unless deco-rated with a metal trim.
Disposable polyester cardboard dishes	●	Some frozen foods are packaged in these dishes.
Fast-food packaging • Polystyrene cups containers • Paper bags or newspaper • Recycled paper or metal trims	● X X	Can be used to warm food. Overheating may cause the polystyrene to melt. May catch fire. May cause arcing.
Glassware • Oven-to-table ware • Fine glassware • Glass jars	● ● ●	Can be used, unless decorated with a metal trim. Can be used to warm foods or liquids. Delicate glass may break or crack if heated suddenly. Must remove the lid. Suitable for warming only.
Metal • Dishes • Freezer bag twist ties	X X	May cause arcing or fire.
Paper • Plates, cups, napkins and Kitchen paper • Recycled paper	● X	For short cooking times and warming. Also to absorb excess moisture. May cause arcing.
Plastic • Containers • Cling film • Freezer bags	● ● ▲	Particularly if heat-resistant thermoplastic. Some other plastics may warp or discolour at high temperatures. Do not use Melamine plastic. Can be used to retain moisture. Should not touch the food. Take care when removing the film as hot steam will escape. Only if boilable or oven-proof. Should not be airtight. Prick with a fork, if necessary.
Wax or grease-proof paper	●	Can be used to retain moisture and prevent spattering.

- : Recommended use
- ▲ : Limited Use
- X : Not Recommended

CONTROL PANEL

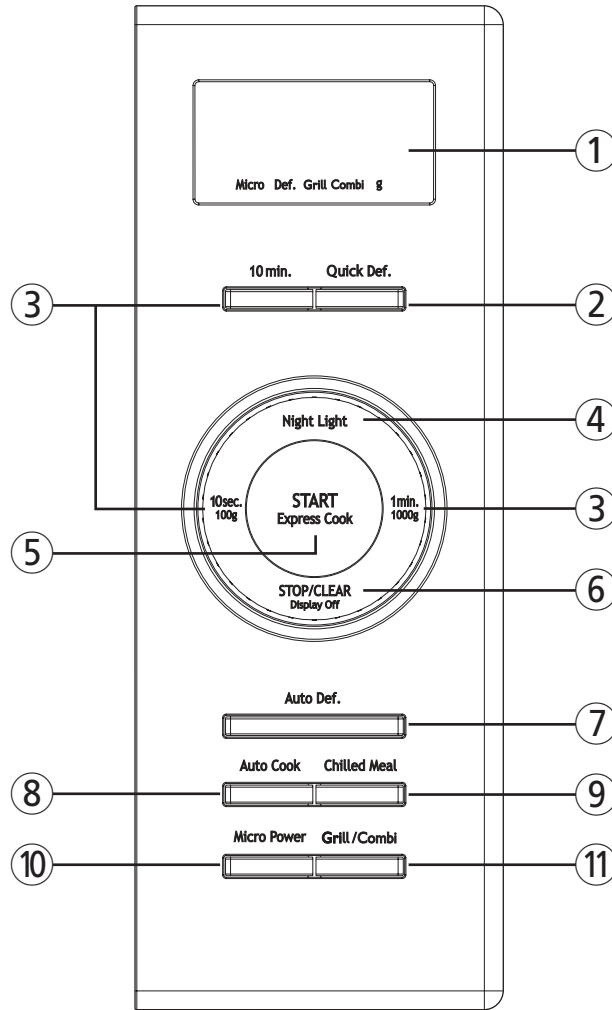

- ① **Display** - Cooking time, power level, indicators are displayed.
- ② **Quick Defrost** - Used to defrost foods very quickly
- ③ **Time Set Pad** - Used to set the cooking time and weight.
- ④ **Night Light** - Used to turn ON/OFF the Night Light.
- ⑤ **Start/Express Cook** - Used to start the oven operation or to increase the reheat time by 30 seconds.
- ⑥ **Stop/Clear** - Used to stop operation the oven or to delete the cooking data.
- ⑦ **Auto Defrost** - Used to defrost foods. (for weight defrost)
- ⑧ **Auto Cook** - Used to cook or reheat many of favorite food.
- ⑨ **Chilled Meal** - Used to reheat meal or dinner plate.
- ⑩ **Micro Power** - Used to set power level.
- ⑪ **Grill/Combi** - Used to cook Grill/Combi.

FEATURES DIAGRAM

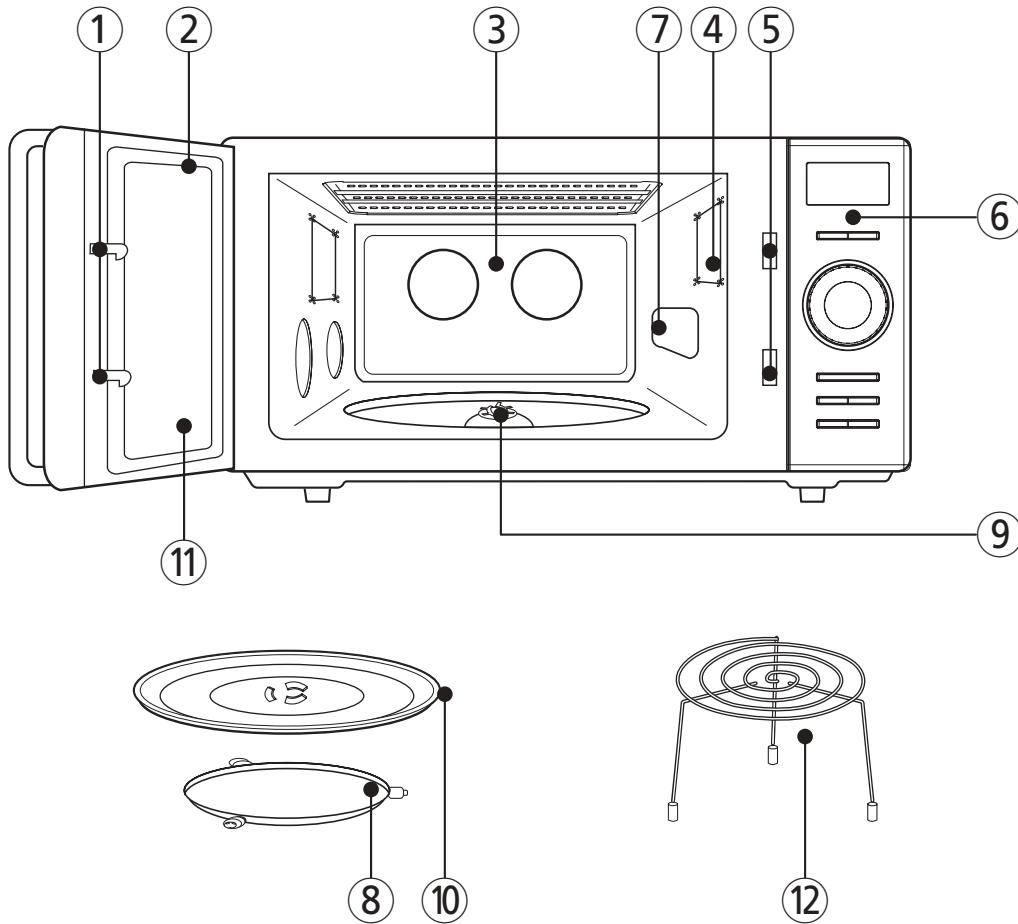

① **Door hook** - When the door is closed, it will automatically lock shut. If door is opened while oven is operating, magnetron tube will immediately stop operating.

② **Door seal** - Door seal maintains the microwave within the oven cavity and prevents microwave leakage.

③ **Oven cavity**

④ **Oven lamp** - Automatically turns on during oven operating.

⑤ **Safety interlock system**

⑥ **Control panel**

⑦ **Spatter shield** - Protects the microwave outlet from splashes of cooking foods.

⑧ **Roller guide** - Supports the glass cooking tray.

⑨ **Coupler** - This fits over the shaft in the center of the oven cavity floor. This is to remain in the oven for all cooking.

⑩ **Glass cooking tray** - Made of special heat resistant glass. The tray must always be in proper position before operating. Do not cook food directly on the tray.

⑪ **Door screen** - Allows viewing of food. Microwave cannot pass through perforations in screen.

⑫ **Metal rack**

OPERATION PROCEDURE

This section includes useful information about oven operation.

- 1** Plug power supply cord into AC 230V / 50Hz power outlet.
- 2** After placing the food in a suitable container, open the oven door and put it on the glass tray. The glass tray and roller guide must always be in place during cooking.
- 3** Close the door. Make sure that it is firmly closed. When the oven door is closed, the light turns off.
- 4** The oven door can be opened at any time during operation by pushing the door open button. The oven will automatically shut off. To restart the oven, close the door and then push the START button.
- 5** The oven automatically cooks on full power unless set to a lower power level.
- 6** The display will show " : 0" when the oven is plugged in.
- 7** Time clock returns to the present time when the cooking time ends.
- 8** When the STOP/CLEAR button is pushed during the oven operation, the oven stops cooking and all information retained. To erase all information(except the present time), push the STOP/CLEAR button once more. If the oven door is opened during the oven operation, all information is retained.
- 9** If the START button is pushed and the oven does not operate, check the area between the door and door seal for obstructions and make sure the door is closed securely. The oven will not start cooking until the door is completely closed or the program has been reset.

Make sure the oven is properly installed and plugged into the electrical outlet.

WATTAGE OUTPUT CHART

- The power-level is set by pressing the POWER pad. The chart shows the display, the power level and the percentage of power.

Touch POWER pad	Power level (Display)	Approximate Percentage of Power
once	P-HI	100%
twice	P-90	90%
3 times	P-80	80%
4 times	P-70	70%
5 times	P-60	60%
6 times	P-50	50%
7 times	P-40	40%
8 times	P-30	30%
9 times	P-20	20%
10 times	P-10	10%
11 times	P-00	0%

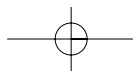

CONTROLS

QUICK DEFROST

When DEFROST is selected, the automatic cycle divides the defrosting time into periods of alternating defrost and stand times by cycling on and off.

- | | | |
|--|---------------------------------------|--|
| <p>Quick Def.</p>  | <p>1. Push the QUICK DEF. button.</p> | <p>The DEFROST indicator lights and "500" is displayed.
The g indicator starts blinking.</p> |
| <p>2. Close the door.</p> | | |
| <p>3. Push the START button.</p> | | |

Use this function to thaw only 500g of minced meat very quickly.
This will require a standing time to allow the center to thaw.

AUTO DEFROST

Auto Defrost lets you easily defrost food by eliminating guess work in determining defrosting time. Follow the steps below for easy defrosting.

- | | | |
|---|--|--|
| <p>Auto Def.</p>  | <p>1. Push the AUTO DEF. button to set the item. (Refer to the auto defrost chart below)</p> | <p>The DEFROST indicator light and "1-1" is displayed.</p> |
| <p>2. Select the desired defrosting weight.</p> | | |
| <p>3. Close the door.</p> | | |
| <p>4. Push the START button.</p> | | |

The display will show what you touched.
The g indicator starts blinking.

MEAT DEFROSTING begins.

* AUTO DEFROST CHART

Push button	MENU	Display	Weight
once	Meat	1-1	200g ~ 2000g
twice	Poultry	1-2	200g ~ 2000g
3 times	Fish	1-3	200g ~ 2000g
4 times	Bread	1-4	100g ~ 500g

The defrosting time is automatically determined by the weight selected.
When you push the START button, the g indicator goes off and the DEF indicator blinks and the defrosting time counts down in the display window. The oven beeps during the defrosting cycle to signal that the food needs to be turned or rearranged. When the defrosting time ends, you will hear 3 beeps.

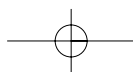

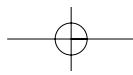

CHILLED MEAL

Chilled Meal



1. Push the CHILLED MEAL button. The display shows "3-1"
2. Select the desired cooking weight. The display will show what you touched.
(Refer to the CHILLED MEAL weight chart)
3. Close the door.
4. Push the START button.

* CHILLED MEAL WEIGHT CHART

Push button	Display	Weight
once	3-1	300g
twice	3-2	400g
3 times	3-3	500g

Pierce using a skewer on the surface.
Place food on the glass turntable. After cooking, arrow to stand for 2-3 minutes before serving.

- Stirrable e.g : Spaghetti bolognese, Beef stew
- Non-stirrable e.g : Lasagne, Cottage pie

NOTE:

For food contained in bag(s), pierce meat portion and rice/pasta portions, etc.

- For stirrable foods, stir at beep.
- Non-stirrable foods, it is not necessary to stir at beep.

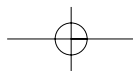

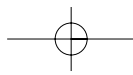

GRILL COOKING

This function allows you to brown food quickly. The heating element is located in the top of the oven. There is no pre-heating the oven for grill cooking. Place food inside the oven when setting the controls.

Grill /Combi



1. Push Grill/Combi button.

The Grill indicator lights and “ : 0” is displayed.

2. Push the time button to adjust the cooking time.

The display will show what you touched.

NOTE: Time can be set up to 30 minutes.

3. Push Start button.

When you push Start button, the Grill indicator starts blinking to show the oven is cooking. The display counts down the time to show how much cooking time is left. When the cooking time ends, you will hear 3 beeps.

COMBI COOKING

The oven has combination mode which cooks food with heater and microwave at the same time. The combination mode accelerates the cooking process.

Grill /Combi



1. Push Grill/Combi button.

The Grill indicator lights and “ : 0” is displayed.

2. Push Grill/Combi button once more.

The Combi indicator lights and “ : 0” is displayed.

3. Push the time button to adjust the cooking time.

The display will show what you touched.

NOTE: Time can be set up to 30 minutes 00 seconds. (30:00)

4. Push Start button.

When you push Start button, the Combi indicator starts blinking to show the oven is cooking. The display counts down the time to show how much cooking time is left. When the cooking time ends, you will hear 3 beeps.

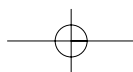

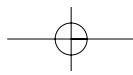

SETTING COOKING TIMES & POWER LEVELS

MICRO POWER



- | | |
|--|---|
| <p>1. Push the MICRO POWER button.
(Select the desired power level.)</p> <p>2. Push the time set pads for the cooking time.</p> <p>3. Close the door.</p> <p>4. Push the START button.</p> | <p>The Micro indicator lights. The display will show what you touched</p> <p>The display will show what you touched</p> |
|--|---|

NOTE: Your oven can be programmed for 30 minutes 00 seconds. (30 : 00)
Using lower power levels increases the cooking time which is recommended for foods such as cheese, milk and slow cooking of meats.

When you push the START button, the M/W indicator starts blinking to show the oven is cooking. The display counts down the time to show how much cooking time is left.

EXPRESS COOK

EXPRESS COOK allows you to reheat for 30 seconds at 100% (full power) by simply pushing the EXPRESS COOK button. By repeatedly pushing the EXPRESS COOK button, you can also extend reheating time to 30 minutes by 30 second increments.

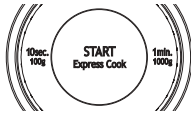

- | | |
|---|--|
| <p>1. Close the door.</p> <p>2. Push the EXPRESS COOK button.</p> | <p>When you push the EXPRESS COOK button, “:30” is displayed, and the oven starts reheating.</p> |
|---|--|

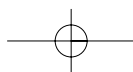

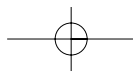

AUTO COOK

AUTO COOK allows you to cook or reheat many of your favorite foods by repeatedly pushing the AUTO COOK button and choosing the desired menu.

Auto Cook



1. Push the AUTO COOK button. once for fresh Vegetable.
2. Push the 10 sec./100g pads for the cooking quantity. (Refer to auto cook chart below)

When you push the AUTO COOK button. "2-1" is displayed.

The display is as shown in the chart below and if the quantity is weight, the g indicator starts blinking.

3. Close the door.

The display will be changed into cooking time of quantity and the oven starts cooking.

4. Push the START button.

* AUTO COOK CHART

Push button	Menu	Display	Weight	Remark																		
Once	Fresh Vegetable	2-1	200g ~ 400g	Trim and wash the mixed vegetables. Place them in the round dish. Add to 2 tbsp. water cover with wrap.																		
Twice	Frozen Vegetable	2-2	200g ~ 400g	Places the vegetables in the round dish. Add to 2 tbsp. water cover with wrap.																		
3 times	Jacket Potatoes	2-3	1 ~ 3ea	Choose medium sized potatoes 200~250g. wash and pierce potatoes with a fork. Place them on the turntable.																		
4 times	Rice/Pasta	2-4	100g ~ 300g	Wash rice, Drain water. Place rice & boiling water with 1/4 to 1teaspoon salt in a deep and large bowl.																		
				<table border="1"> <thead> <tr> <th colspan="2">Weight</th> <th>100g</th> <th>200g</th> <th>300g</th> <th>Cover</th> </tr> </thead> <tbody> <tr> <td>Water</td> <td>Rice</td> <td>180ml</td> <td>330ml</td> <td>480ml</td> <td>o</td> </tr> <tr> <td></td> <td>Pasta</td> <td>400ml</td> <td>800ml</td> <td>1200ml</td> <td>x</td> </tr> </tbody> </table>	Weight		100g	200g	300g	Cover	Water	Rice	180ml	330ml	480ml	o		Pasta	400ml	800ml	1200ml	x
				Weight		100g	200g	300g	Cover													
				Water	Rice	180ml	330ml	480ml	o													
	Pasta	400ml	800ml	1200ml	x																	
* Rice - After cooking, stand covered for 5 minutes until water is absorbed.																						
* Pasta - During the cooking, stir several times. After cooking, stand for 3 or 5 minutes with cover. Rinse pasta with cold water.																						
				• Use only refrigerated foods.																		
5times	Pizza Reheat	2-5	1 ~ 3 pices	<ul style="list-style-type: none"> • Put the pizza on a microwave-safe plate with wide end of slice towards the outside edge of the plate. • Do not let slices overlap. Do not cover. • Before serving, let stand 1~2min. 																		

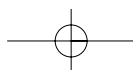

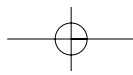

NIGHT LIGHT



1. Push the NIGHT LIGHT button.
2. Push the NIGHT LIGHT button again.

If you push NIGHT LIGHT button once, the night light turns ON.

If you push NIGHT LIGHT button again, the night light turns OFF.

CHILD SAFETY LOCK

The safety lock prevents unwanted oven operation such as by small children. To set, touch and hold STOP/CLEAR for 3 seconds. To cancel, touch and hold STOP/CLEAR for 3 seconds.

HOW TO STOP THE OVEN WHILE THE OVEN IS OPERATING

1. Push STOP/CLEAR button.
 - You can restart the oven by touching START button.
 - Touch STOP/CLEAR once more to erase all instructions.
 - You must enter in new instructions.
2. Open the door.
 - You can restart the oven by closing the door and touching START.

NOTE: Oven stops operating when door is opened.

ARCING

If you see arcing, push the STOP/CLEAR button and correct the problem.

Arcing is the microwave term for sparks in the oven.

Arcing is caused by:

- Metal or foil touching the side of the oven.
- Foil not molded to food (upturned edges act like antennas).
- Metal, such as twist-ties, poultry pins, or gold rimmed dishes, in the microwave.
- Recycled paper towels containing small metal pieces being used in the microwave.

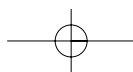

GENERAL GUIDE LINES

Since microwave cooking to some extent is different from traditional cooking, the following general guidelines should be considered whenever you use your microwave oven

If the food is undercooked

Check if:

- You have selected the correct power level.
- The selected time is sufficient-the times given in the recipes are approximate. They depend on initial temperature, weight and density of the food etc.
- The container is appropriate.

If the food is overcooked, i.e. dried out or burnt

Before you cook again, consider whether:

- The power level was too high.
- The set time was too long-the times in the recipes are approximate. They depend on initial temperature, weight and density of the food etc.

Points to remember when defrosting

- The shape of the package alters the defrosting time. Shallower rectangular packets defrost more quickly than a deep block. Separate pieces as they begin to defrost; free flow slices defrost more easily.
- Shield areas of food with small pieces of foil if they start to become warm.
- When defrosting, it is better to under thaw the food slightly and allow the process to finish during the standing time.

The amount of food

The more food you want to prepare the longer it takes. A rule of thumb is that double amount of food requires almost double the time. If one potato takes four minutes to cook, approximately seven minutes are required to cook two potatoes.

Starting temperature of food

The lower the temperature of the food which is being put into the microwave oven, the longer time it takes. Food at room temperature will be reheated more quickly than food at refrigerator temperature.

Composition of the food

Food with a lot of fat and sugar will be heated faster than food containing a lot of water. fat and sugar will also reach a higher temperature than water in the cooking process. The more dense the food, the longer it takes to heat. "Very dense" food like meat takes longer time to reheat than lighter, more porous food like sponge cakes.

Size and shape

Smaller pieces of food will cook more quickly than larger pieces and uniform pieces of food cook more evenly than irregularly shaped foods.

With unevenly shaped food, the thinner parts will cook faster than the thicker areas. Place the thinner chicken wings and legs to the centre of the dish.

Stirring, turning of foods

Stirring and turning of foods are techniques used in conventional as well as in microwave cooking to distribute the heat quickly to the centre of the dish and avoid over-cooking at the outer edges of the food.

Covering food helps:

- To reduce spattering
- To shorten cooking times
- To retain food moisture

All covering, which will allow microwaves to pass through are suitable-See page 5 "Which utensils can be used in the oven?"

Releasing pressure in foods

Several foods are tightly covered by a skin or membrane. These foods should be pricked with a fork or cocktail stick to release the pressure and to prevent bursting, as steam builds up within them during cooking. This applies to potatoes, chicken livers, sausages, egg yolks and some fruits.

Standing time

Always allow the food to stand for some time after using the oven. standing time after defrosting, cooking/reheating always improves the result since the temperature will then be evenly distributed through out the food.

In a microwave oven food continues to cook even when the microwave energy is turned off. It is no longer cooking by microwaves, but still being cooked by the conduction of the high residual heat to the centre of the food.

The length of standing time depends on the volume and density of the food. Sometimes it can be as short as the time it takes you to remove the food from the oven and take it to the serving table. However, with larger, denser foods, the standing time may be as long as 10 minutes. During 'standing', the internal temperature of the food will rise by as much as 8°C and the food will finish cooking in this time.

Arranging food

This is done in several ways in microwave cooking to give more even cooking results.

If you are cooking several items of the same food such as jacket potatoes, place them in a ring pattern for uniform cooking. When cooking foods of uneven shapes or thickness, place the smaller or thinner area of the food towards the centre of the dish where it will be heated last.



Uneven foods such as fish should be arranged in the oven with the tails to the centre.

If you are saving a meal in the refrigerator or 'plating' a meal for reheating, arrange the thicker, denser foods to the outside of the plate and the thinner or less dense foods in the middle.

Place thin slices of meat on top of each other or interlace them. Thicker slices such as meat loaf and sausages have to be placed close to each other. Gravy or sauce should be reheated in a separate container.



Choose a tall, narrow container rather than a low and wide container. When reheating gravy, sauce or soup, do not fill the container more than 2/3.



When you cook or reheat whole fish, score the skin this prevents cracking.

Shield the tail and head with small pieces of foil to prevent over-cooking but ensure the foil does not touch the sides of the oven.



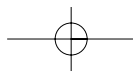

CARE AND CLEANING

Although your oven is provided with safety features, it is important to observe the following:

- 1** It is important not to defeat or tamper with safety interlocks.
- 2** Do not place any object between the oven front face and the door or allow residue to accumulate on sealing surfaces. Wipe the sealing area frequently with a mild detergent, rinse and dry. Never use abrasive powders or pads.
- 3** When opened, the door must not be subjected to strain, for example, a child hanging on an opened door or any load could cause the oven to fall forward to cause injury and also damage to the door. Do not operate the oven if it is damaged, until it has been repaired by a competent service technician. It is particularly important that the oven closes properly and that there is no damage to the:
 - i) Door(bent)
 - ii) Hinges and Hookes(broken or loosened)
 - iii) Door seals and sealing surfaces.
- 4** The oven should not be adjusted or repaired by anyone except a properly competent service technician.
- 5** The oven should be cleaned regularly and any food deposits removed;
- 6** Failure to maintain the oven in a clean condition could lead to deterioration of the surface that could adversely affect the life of the appliance and possibly result in a hazardous situation.

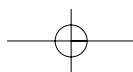
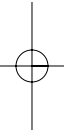
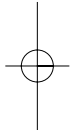

BEFORE CALLING FOR SERVICE

You can often correct operating problems yourself. If your microwave/grill oven fails to work properly, locate the operating problem in the chart below and try the solutions marked for each problem.

If the microwave/grill oven still does not work properly, contact the nearest Service Centre.

Note:

It is quite normal for steam to be emitted around the door during the cooking cycle. The door is not intended to seal the oven cavity completely but its special design contributes to the complete safety of the appliance.

Caution:

1. Do not attempt to operate the oven while empty as this will cause damage.
2. As an exhaust is located in the rear of the oven, install the oven so as not to block the outlet.
If the microwave/grill oven still does not work properly, contact the nearest Service Centre.

PROBLEM	1	2	3	4	5	6	7	8	9	10	11	12
Oven will not start	X	X	X	X								
Arcing or sparking					X	X						
Unevenly cooked foods					X		X	X	X			
Overcooked foods										X		
Undercooked foods					X				X	X	X	
Improper defrosting					X		X	X		X		X

SOLUTION	1	2	3	4	5	6	7	8	9	10	11	12
Is start button pressed?	—											
Is power cord plugged in?		—										
Is door closed?			—									
Set the cooking time.				—								
Use approved cookware only.					—							
Do not operate with oven empty.						—						
Supplied tray must be used.							—					
Turn or stir food.								—				
Completely defrost food.									—			
Turn correct dial knob / Press correct Function buttons										—		
Check to see that oven ventilation parts are not blocked.											—	
Do "manual cooling" over 10 minutes.												—

QUESTIONS AND ANSWERS

*** Q : I accidentally ran my microwave oven without any food in it. Is it damaged?**

A : Running the oven empty for a short time will not damage the oven. However, it is not recommended.

*** Q : Can the oven be used with the glass tray or roller guide removed?**

A : No. Both the glass tray and roller guide must always be used in the oven before cooking.

*** Q : Can I open the door when the oven is operating?**

A : The door can be opened anytime during the cooking operation. Then microwave energy will be instantly switched off and the time setting will maintain until the door is closed.

*** Q : Why do I have moisture in my microwave oven after cooking?**

A : The moisture on the side of your microwave oven is normal. It is caused by steam from cooking food hitting the cool oven surface.

*** Q : Does microwave energy pass through the viewing screen in the door?**

A : No. The metal screen bounces back the energy to the oven cavity. The holes are made to allow light to pass through. They do not let microwave energy pass through.

*** Q : Why do eggs sometimes pop?**

A : When baking or poaching eggs, the yolk may pop due to steam build-up inside the yolk membrane. To prevent this, simply pierce the yolk with a toothpick before cooking. Never cook eggs without piercing their shells.

*** Q : Why this standing time recommended after the cooking operation has been completed?**

A : Standing time is very important. With microwave cooking, the heat is in the food, not in the oven. Many foods build up enough internal heat to allow the cooking process to continue, even after the food is removed from the oven. Standing time for joints of meat, large vegetables and cakes is to allow the inside to cook completely, without overcooking the outside.

*** Q : What does "standing time" mean?**

A : "Standing time" means that food should be removed from the oven and covered for additional time to allow it to finish cooking. This frees the oven for other cooking.

*** Q : Why does my oven not always cook as fast as the microwave cooking guide says?**

A : Check your cooking guide again, to make sure you've followed directions exactly ; and to see what might cause variations in cooking time. Cooking guide times and heat settings are suggestions, to help prevent overcooking... the most common problem in getting used to a microwave oven. Variations in the size, shape and weights and dimensions could require longer cooking time. Use your own judgment along with the cooking guide suggestions to check whether the food has been properly cooked just as you would do with a conventional cooker.

*** Q : Will the microwave oven be damaged if it operates while empty?**

A : Yes. Never run it empty.

*** Q : Can I operate my microwave oven without the turntable or turn the turntable over to hold a large dish?**

A : No. If you remove or turn over the turntable, you will get poor cooking results. Dishes used in your oven must fit on the turntable.

*** Q : Is it normal for the turntable to turn in either direction?**

A : Yes. The turntable rotates clockwise or counterclockwise, depending on the rotation of the motor when the cooking cycle begins.

*** Q : Can I pop popcorn in my microwave oven? How do I get the best results?**

A : Yes. Pop packaged microwave popcorn following manufacture's guidelines. Do not use regular paper bags. Use the "listening test" by stopping the oven as soon as the popping slows to a "pop" every 1 or 2 seconds. Do not re-pop unpopped kernels. Do not pop popcorn in glass cookware.

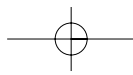

SPECIFICATIONS

POWER SUPPLY		230V~50Hz, SINGLE PHASE WITH EARTHING
POWER CONSUMPTION	MICROWAVE	1200 W
	GRILL	1050 W
	COMBINATION	2200 W
MICROWAVE ENERGY OUTPUT		800W
MICROWAVE FREQUENCY		2450MHz
OUTSIDE DIMENSIONS (W x H x D)		465 x 287 x 347mm
CAVITY DIMENSIONS (W x H x D)		298 x 230 x 330mm
NET WEIGHT		APPROX. 12.7Kg
TIMER		30 min 00 sec.
POWER SELECTIONS		10 LEVELS

* Specifications are subject to change without notice.

PRINCIPLE OF MICROWAVE

Microwave oven is a Group 2 ISM equipment in which radio-frequency energy is intentionally generated and used in the form of electromagnetic radiation for the treatment of material. This oven is a Class B equipment suitable for use in domestic establishments and in establishments directly connected to a low voltage power supply network which supplies buildings used for domestic purposes.

DISPOSAL OF USED ELECTRICAL & ELECTRONIC EQUIPMENT



The meaning of the symbol on the product, its accessory or packaging indicates that this product shall not be treated as household waste. Please, dispose of this equipment at your applicable collection point for the recycling of electrical & electronic equipments waste. In the European Union and Other European countries which there are separate collection systems for used electrical and electronic product. By ensuring the correct disposal of this product, you will help prevent potentially hazardous to the environment and to human health, which could otherwise be caused by unsuitable waste handling of this product. The recycling of materials will help conserve natural resources. Please do not therefore dispose of your old electrical and electronic equipment with your household waste. For more detailed information about recycling of this product, please contact your local city office, your household waste disposal service or the shop where you purchased the product.

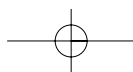

COOKING TECHNIQUES

STANDING TIME

Dense foods e.g. meat, jacket potatoes and cakes, require standing time(inside or outside of the oven) after cooking, to allow heat to finish conducting to cook the center completely. Wrap meat joints and jacket potatoes in aluminum foil while standing. Meat joints need approx. 10-15 minutes, jacket potatoes 5 minutes. Other foods such as plated meal, vegetables, fish etc require 2-5 minutes standing. After defrosting food, standing time should also be allowed. If food is not cooked after standing time, return to the oven and cook for additional time.

MOISTURE CONTENT

Many fresh foods e.g. vegetables and fruit, vary in their moisture content throughout the season, particularly jacket potatoes. For this reason cooking times may have to be adjusted. Dry ingredients e.g. rice, pasta, can dry out during storage so cooking times may differ.

DENSITY

Porous airy foods heat more quickly than dense heavy foods.

CLING FILM

Cling film helps keep the food moist and the trapped steam assists in speeding up cooking times. Pierce before cooking to allow excess steam to escape. Always take care when removing cling film from a dish as the build-up of steam will be very hot.

SHAPE

Even shapes cook evenly. Food cooks better by microwave when in a round container rather than square.

SPACING

Foods cook more quickly and evenly if spaced apart. NEVER pile foods on top of each other.

STARTING TEMPERATURE

The colder the food, the longer it takes to heat up. Food from a fridge takes longer to reheat than food at room temperature.

LIQUIDS

All liquids must be stirred before and during heating. Water especially must be stirred before and during heating, to avoid eruption. Do not heat liquids that have previously been boiled. DO NOT OVERHEAT.

TURNING & STIRRING

Some foods require stirring during cooking. Meat and poultry should be turned after half the cooking time.

ARRANGING

Individual foods e.g. chicken portions or chops, should be placed on a dish so that the thicker parts are towards the outside.

QUANTITY

Small quantities cook faster than large quantities, also small meals will reheat more quickly than large portions.

PIERCING

The skin or membrane on some foods will cause steam to build up during cooking. These foods must be pierced or a strip of skin should be peeled off before cooking to allow the steam to escape. Eggs, potatoes, apples, sausages etc, will all need to be pierced before cooking. DO NOT ATTEMPT TO BOIL EGGS IN THEIR SHELLS.

COVERING

Cover foods with microwave cling film or a lid. Cover fish, vegetables, casseroles, soups. Do not cover cakes, sauces, jacket potatoes or pastry items.

DEFROSTING GUIDE

- ▶ Do not defrost covered meat. Covering might allow cooking to take place. Always remove outer wrap and tray. Use only containers that are microwave-safe.
- ▶ Begin defrosting whole poultry breast-side-down. Begin defrosting roasts fat-side-down.
- ▶ The shape of the package alters the defrosting time. Shallow rectangular shapes defrost more quickly than a deep block.
- ▶ After $\frac{1}{3}$ of the defrost time has elapsed, check the food. Toy may wish to turn over, break apart, rearrange or remove thawed portions of the food.
- ▶ During defrost, the oven will prompt you to turn the over. At this point, open oven door and check the food. Follow the techniques listed below for optimum defrost results.
Then, close oven door, push the START button to complete defrosting.
- ▶ When defrosted, food should be cool, but softened in all areas. If still slightly icy, return to microwave oven very briefly, or let stand a few minutes. After defrosting, allow food to stand 5-60 minutes if there are any icy areas.
Poultry and fish may be placed under running cool water until defrosted
- ⇨ **Turn over** : Roast, ribs, whole poultry, turkey breasts, hot dogs, sausages, steaks, or chops.
- ⇨ **Rearrange** : Break apart or separate steaks, chops, hamburger patties, ground meat, chicken or seafood pieces and chunks of meat such as stew beef.
- ⇨ **Shield** : Use small strips of aluminum foil to protect thin areas or edges of unevenly shaped foods such as chicken wings. To prevent arching, do not allow foil to come within 1-inch of oven walls or door.
- ⇨ **Remove** : To prevent cooking, thawed portions should be removed from the oven at this point. This may shorten defrost time for food weighing less than 3 lbs.(1350g).

DEFROSTING CHART

Item & Weight	Defrosting Time	Standing Time	Special Techniques
BEEF			
Minced beef 1 lb./450g	11-12 min.	15-20 min.	Break apart and remove thawed portions with fork.
Stew Meat 1 1/2 lbs./675g	14-16 min.	25-30 min.	Separate and rearrange once.
Patties 4(4oz./110g)	10-12 min.	15-20 min.	Turn over after half the time.
PORK			
Spareribs 1 lb./450g	11-12 min.	25-30 min.	Separate and rearrange once.
Chops 4(5oz./125g)	8-10 min.	25-30 min.	Separate and turn over once.
Minced pork 1 lb./450g	10-12 min.	15-20 min.	Break apart and remove thawed portions with fork.
POULTRY			
Whole Chicken 2 1/2 lbs./1125g	23-25 min.	45-90 min.	Break side down. Turn over after half the time. Shield as needed.
Chicken Breasts 1 lbs./450g	11-12 min.	15-30 min.	Separate and rearrange once.
Fryer Chicken(cut up) 2 lbs./900g	19-21 min.	25-30 min.	Separate and rearrange once.
Chicken Thights 1 1/2 lbs./675g	14-16 min.	15-30 min.	Separate and rearrange once.
FISH & SEAFOOD			
Whole Fish 1 lb./450g	8-10 min.	15-20 min.	Turn over after half the time. Shield as needed.
Fish Fillets 1 1/2 lb./675g	13-15 min.	15-20 min.	Separate and turn over once.
Shrimp 1/2 lb./225g	4-5 min.	15-20 min.	Separate and rearrange once.

* The times are approximate because freezer temperatures vary.

COOKING & REHEATING CHART

Item	Power Level	Cooking Time Per lb./450g		
MEAT				
Beef				
Standing / rolled Rib - Rare	P-80	7-9 min.		
- Medium	P-80	8-10 min.		
- well done	P-80	10-12 min.		
Ground Beef (to brown for casserole)	P-HI	4-6 min.		
Hamburgers, Fresh or defrosted (4oz. Each/100g) 2 patties	P-HI	3-5 min.		
4 patties	P-HI	4-6 min.		
Pork				
Loin, Leg	P-80	11-14 min.		
Bacon 4 slices	P-HI	2-3 min.		
6 slices	P-HI	3-4 min.		
NOTE: The above times should be regarded only as a guide. Allow for difference in individual lasts and preferences. The times may vary due to the shape, cut, and composition of the meat.				
POULTRY				
Chicken				
Whole	P-HI	6-8 min.		
Breast(boned) portions	P-80	5-7 min.		
	P-80	6-8 min.		
Turkey				
Whole	P-HI	10-12 min.		
NOTE : The above times should be regarded only as a guide. Allow for difference in individual tastes and preferences. The times may vary due to the shape, cut, and composition of the food.				
FRESH FISH				
Item	Power Level	Cooking Time Per lb./450g	Method	Standing Time
Fish Fillets	P-HI	4-6 min.	Add 15-30 ml(1-2 Tbsp)	2-3 min.
Whole Mackerel, Cleaned and Prepared	P-HI	4-6 min.	-	3-4 min.
Whole Trout, Cleaned and Prepared	P-HI	5-7 min.	-	3-4 min.
Salmon Steaks	P-HI	5-7 min.	Add 15-30 ml(1-2 Tbsp)	3-4 min.
ITEM	POWER LEVEL	Cooking Time	Standing Time	
Lasagna 1 serving(10 1/2 oz./300g)	P-HI	5-7 min.	Place lasagna on microwaveable plate. Cover with plastic wrap and vent.	
Casserole 1 cup	P-HI	1 1/2 -3 min.	Cook covered in, microwaveable dish(casserole).	
4 cups	P-HI	5-7 min.	Stir once halfway through cooking.	
Mashed potatoes 1 cup	P-HI	2-3 min.	Cook covered in, microwaveable dish(casserole).	
4 cups	P-HI	6-8 min.	Stir once halfway through cooking.	
Baked beans 1 cup	P-HI	2-3 min.	Cook covered in, microwaveable dish(casserole). Stir once halfway through cooking.	
Ravioli or pasta in sauce 1 cup	P-HI	3-4 min.	Cook covered in, microwaveable dish(casserole).	
4 cups	P-HI	8-11 min.	Stir once halfway through cooking.	
Sandwich roll or bun 1 roll	P-HI	20-30 sec.	Wrap in paper tower and place on glass microwaveable rack * Note : Do not use recycled paper towels.	

VEGETABLE CHART

Use a suitable glass Pyrex bowl with lid. Add 30-45ml cold water(2-3 tbsp.) for every 250g unless another water quantity is recommended - see table. Cook covered for the minimum time - see table. Continue cooking to get the result you prefer. Stir once during and once after cooking. Add salt, herbs or butter after cooking. Cover during a standing time of 3 minutes.

Hint : cut the fresh vegetables into even sized pieces. The smaller they are cut, the quicker they will cook.

All vegetables should be cooked using full microwave power.

Cooking Guide for fresh vegetables

Vegetables	Weight	Time	Comments
Broccoli	1/2 lb./250g 1 lb./500g	3-4 min 5-7 min	Prepare even sized florets. Arrange the stems to the centre.
Brussels sprouts	1/2 lb./250g	4-5 min	Add 60-75ml(5-6tbsp.) water.
Carrots	1/2 lb./250g	3-4 min	Cut carrots into even sized slices.
Cauliflower	1/2 lb./250g 1 lb./500g	3-4 min 5-7 min	Prepare even sized florets. Cut big florets into halves. Arrange stems to the centre.
Courgettes	1/2 lb./250g	3-4 min	Cut courgettes into slices. Add 30ml(2tbsp.) water or a knob of butter. Cook until just tender.
Egg plants	1/2 lb./250g	3-4 min	Cut egg plants into small slices and sprinkle with 1 tablespoon lemon juice.
Leeks	1/2 lb./250g	3-4 min	Cut leeks into thick slices.
Mushrooms	0.3 lb./125g 1/2 lb./250g	2-3 min 3-5 min	Prepare small whole or sliced mushrooms. Do not add any water. Sprinkle with lemon juice. Spice with salt and pepper. Drain before serving.
Onions	1/2 lb./250g	3-4 min	Cut onions into slices or halves. Add only 15ml(1tbsp.) water.
Pepper	1/2 lb./250g	3-5 min	Cut pepper into small slices.
Potatoes	1/2 lb./250g 1 lb./500g	3-5 min 8-10 min	Weigh the peeled potatoes and cut them into similar sized halves or quarters.
Turnip cabbage	1/2 lb./250g	5-7 min	Cut turnip cabbage into small cubes.

Cooking Guide for frozen vegetables

Vegetables	Weight	Time	Instructions
spinach	0.3 lb./125g	2-3 min	Add 15ml(1tbsp.) cold water.
broccoli	1/2 lb./250g	4-5 min	Add 30ml(2 tbsp.) cold water.
Peas	1/2 lb./250g	3-4 min	Add 15ml(1 tbsp.) cold water.
Green beans	1/2 lb./250g	4-5 min	Add 30ml(2tbsp.) cold water.
Mixed vegetables (carrots/peas/corn)	1/2 lb./250g	4-6 min	Add 15ml(1tbsp.) cold water.
Mixed vegetables (Chinese style)	1/2 lb./250g	4-6 min	Add 15ml(1 tbsp.) cold water.

RECIPES

TOMATO & ORANGE SOUP

1 oz.(25g) butter
 1 medium onion, chopped
 1 large carrot & 1 large potato, chopped
 1³/₄lb(800g) canned, chopped tomatoes
 juice and grated rind of 1 small orange
 1¹/₂pints(900ml) hot vegetable stock
 salt and pepper to taste

1. Melt the in a large bowl on P-HI for 1 minute.
2. Add the onion, carrot and potato and cook on P-HI for 6 minutes. stir halfway through cooking.
3. Add the tomatoes, orange juice, orange rind and stock. Mix thoroughly. Season with salt and pepper to taste. Cover the bowl and cook on P-HI for 15 minutes. stir 2-3 times during cooking, until the vegetables are tender.
4. Blend and serve immediately.

FRENCH ONION SOUP

1 large onions, sliced
 1 tbsp (15ml) corn oil
 2 oz.(50g) plain flour
 2 pints(1.2 liters) hot meat
 or vegetable stock
 salt and pepper to taste
 2 tbsp (30ml) parsley, chopped
 4 thick slices French bread
 2 oz.(50g) cheese, grated

1. Place the onion and oil a bowl, mix well and cook on P-HI for 2 minutes.
2. Stir in the flour to make a paste and gradually add stock. Season and add the parsley.
3. Cover the bowl and cook on P-80 for 16 minutes.
4. Pour the soup into serving bowls, submerge bread and sprinkle generously with cheese.
5. Cook on P-80 for 2 minutes, until the cheese has melted.

STIR FRIED VEGETABLES

1 tbsp(15ml) sunflower oil
 2 tbsp (30ml) soy sauce
 1 tbsp (15ml) sherry
 1"(2.5cm) root ginger,
 peeled and finely grated
 2 medium carrots, cut into fine strips
 4 oz.(100g) button mushrooms,
 chopped
 2 oz.(50g) beansprouts
 4 oz.(100g) mange-tout
 1 red pepper, seeded and thinly sliced
 4 spring onions, chopped
 4 oz.(100g) canned water chestnuts,
 sliced
 1/4 head of chinese leaves, thinly sliced

1. Place the oil, soy sauce, sherry, ginger, garlic and carrots in a large bowl, mix thoroughly
2. Cover and cook on P-HI for 4-5 minutes, stirring once.
3. Add the button mushrooms, beansprouts, mange-tout, red pepper, spring onions, water chestnuts and chinese leaves. Mix thoroughly.
4. Cook on P-HI for 4-5 minutes, until the vegetables are tender. Stir 2-3 times during cooking.

Stir fried vegetables are ideally served with meat or fish.

HONEYED CHICKEN

4 boneless chicken breasts
 2 tbsp(30ml) clear honey
 1 tbsp(15ml) whole grain mustard
 1/2 tsp(2.5ml) dried tarragon
 1 tbsp(15ml) tomato puree
 1/4 pint(150ml) chicken stock

1. Place the chicken breasts in a casserole dish.
2. Mix all remaining ingredients together and pour over the chicken. Salt and pepper to taste.
3. Cook on P-HI for 11-12 minutes. Rearrange and coat the chicken with the sauce twice during cooking.

BLUE CHEESE & CHIVE JACKETS

2 baking potatoes,
 (approx.9 oz.(250g) each)
 2 oz.(50g) butter
 4 oz.(100g) blue cheese, chopped
 1 tbsp(15ml) fresh chives, chopped
 2 oz.(50g) mushrooms, sliced
 salt and pepper to taste

1. Prick each potato in several places. Cook on P-HI for 10-11 minutes. Halve and scoop the flesh into a bowl, add the butter, cheese, chives, mushrooms, salt and pepper, mix thoroughly.
2. Pile mixture into the potato skins and place in a flan dish, on the rack.
3. Cook on P-80 for 10 minutes.

WHITE SAUCE

1 oz.(25g) butter
 1 oz.(25g) plain flour
 1/2 pint(300ml) milk
 salt and pepper to taste

1. Place the butter in a bowl and cook on P-HI for 1 minutes, until melted.
2. Stir in the flour and whisk in the milk. Cook on P-HI for 3-4 minutes, stirring every 2 minutes until thick and smooth. Season with salt and pepper to taste.

STRAWBERRY JAM

1 1/2 lb.(675g) strawberries, hulled
 3 tbsp(45ml) lemon juice
 1 1/2 lb.(675g) caster sugar

1. Place strawberries and lemon juice in a very large bowl, heat on P-HI for 5 minutes, or until the fruit has softened. Add sugar, mix well.
2. Cook on P-80 for 25-30 minutes, until setting point* is reached, stir every 4-5 minutes.
3. Pour into hot, clean jars. Cover, seal and label.

**setting point : To determine setting point, place 1 tsp(5ml)jam onto chilled saucer. Allow to stand for 1 minute. Move surface of jam gently with your finger, if the surface wrinkles setting point has been reached.*

PLAIN MICROWAVE CAKE

4 oz.(100g) margarine
 4 oz.(100g) sugar
 1 eggs
 4 oz.(100g) self raising flour, sifted
 2-3 tbsp(30-45ml) milk

1. line the base of 8" (20.4cm) cake dish with grease-proof paper.
2. Cream the margarine and sugar together until light and fluffy. Beat in the eggs and fold in the sifted flour alternately with the milk.
3. Pour into prepared container. Cook on P-HI for 3-4 minutes, until a skewer comes out cleanly.
4. Leave the cake to stand for 5 minutes before turning out.

OMELETTES

1/2 oz.(15g) butter
 4 eggs
 6 tbsp(90ml) milk
 salt & pepper

1. Whisk together eggs and milk. Season.
2. Place butter in 10"(26cm) flan dish. Cook on P-HI for 1 minutes, until melted. Coat the dish with the melted butter.
3. Pour omelette mixture into flan dish. Cook on P-HI for 2 minutes. whisk mixture and cook again on P-HI for 1 minutes.

SCRAMBLED EDD

1/2 oz.(15g) butter
 2 eggs
 2 tbsp(30ml) milk
 salt & pepper

1. Melt the butter in a bowl on P-HI for 1 minutes.
2. Add the eggs, milk and seasoning and mix well.
3. Cook on P-HI for 2 minutes, stirring every 30 seconds.

SAVORY MINCE

1 small onion, diced
 1 clove garlic, crushed
 1 tsp(5ml) oil
 7 oz.(200g) can chopped tomatoes
 1 tbsp(15ml) tomato puree
 1 tsp(5ml) mixed herbs
 8 oz.(225g) minced beef
 salt and pepper

1. Place onion, garlic and oil in casserole, and cook on P-HI for 2 minutes or until soft.
2. Place all other ingredients in casserole. Stir well.
3. Cover and cook on P-HI for 4 minutes then P-80 for 8-12 minutes or until the meat is cooked.